

The Antenna Elevator

The closest thing to a skyhook.

by Frank DiStefano WB2DZF

No longer do you need to test your nerves and risk your life to repair nature's wear and tear on your beam antenna. Build this simple Antenna Sled and bring your problems down to earth.

Background

Ten years ago at a hamfest I acquired 70' of Rohn 45G tower. On top of this I put a Wilson System 40 triband beam antenna. This was no small project as this antenna has 10 elements with four full-sized 20 meter elements on a 26-foot boom, all weighing in at 80 pounds. After much strain and wild and dangerous gyrations, the antenna was put in place and proved to be an excellent antenna. Now this all sounds great, but what do you do when you have to make repairs or adjustments?

Initially I thought it would have been nice to have an elevator on the side of the tower to raise or lower the whole assembly (antenna, mast and rotator), but my climber had been eager to get the installation completed before winter set in, and I capitulated. That was a mistake. Within a short time the antenna showed a high SWR and it was intermittent in a wind: a loose connection, but where? So, the antenna just sat there for a few years until the ice storm of '91 finished

it off! Part of the antenna fell to the ground and the rest was lowered in a somewhat controlled fall. I rebuilt the antenna but I had to come up with a way to raise it. I was not going to go through the previous experience again.

A Better Way to Raise It

I had to come up with something to lift the antenna to its mounting height, but the tower guys were a major obstacle. So I devised an "elevator" that allows the antenna to be raised by disconnecting the lower guys, raising the antenna, reconnecting the lower guys, disconnecting the upper guys, raising the antenna further and reconnecting the upper guys.

While there is some climbing to bolt the unit to the tower, the heavy work of wrestling the cumbersome beam is eliminated. The antenna can be brought down to within seven feet of the ground. This allows me to work on a small stepladder to make repairs and adjustments.

The unit is guided by two guide wires anchored at the top and bottom. These wires (or cables) are attached to a piece of angle bolted to the tower and passed through four guides welded to the elevator. With the elevator at its raised position it is bolted to the

tower with eight 1-1/2" x 1/4" "U" bolts.

The elevator is raised to its position by means of a boat trailer winch fitted with 3/16" cable which runs through a block at the top of the tower, then back down to the bottom of the elevator. For the top bearing I made a bushing out of plastic. A bearing supplied by the tower manufacturer could be easily adapted if you prefer not to make your own. The mast is made of 2" pipe and the weight of both the antenna and the mast is carried by the rotator.

Appropriate threading of the feedline and rotator wires are key to allowing the antenna to be lowered within easy reach of the ground. Start by threading the feedline and rotator wires inside the tower until you reach the tower midpoint. Then bring all the wires outside of the tower and back down to your waiting antenna. Now, hookup and testing can be done on the ground.

Now you are ready to lift your assembly to the top of the tower. When in place, you can tape or wire-tie the wires to the tower.

I much prefer the guyed tower to the free-standing tower because I don't want any concrete to contend with when installing or removing the tower at a later date. The elevator is made of 3/16" x 2" angle iron and is of welded construction. While you could

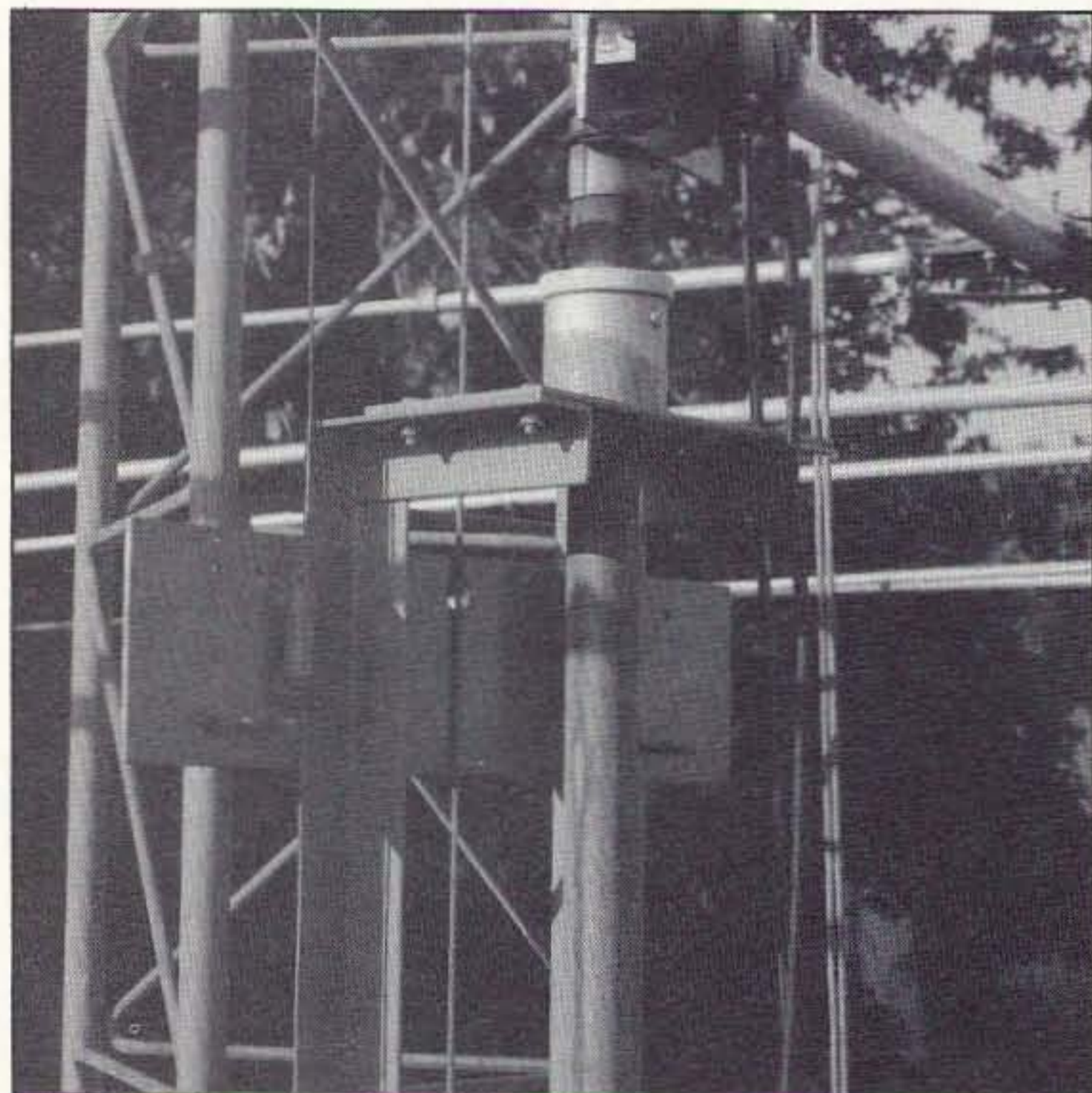

Photo A. The mast bearing and guide wires passing through their guides. The hoisting cable can be seen passing down to the bottom of the elevator.

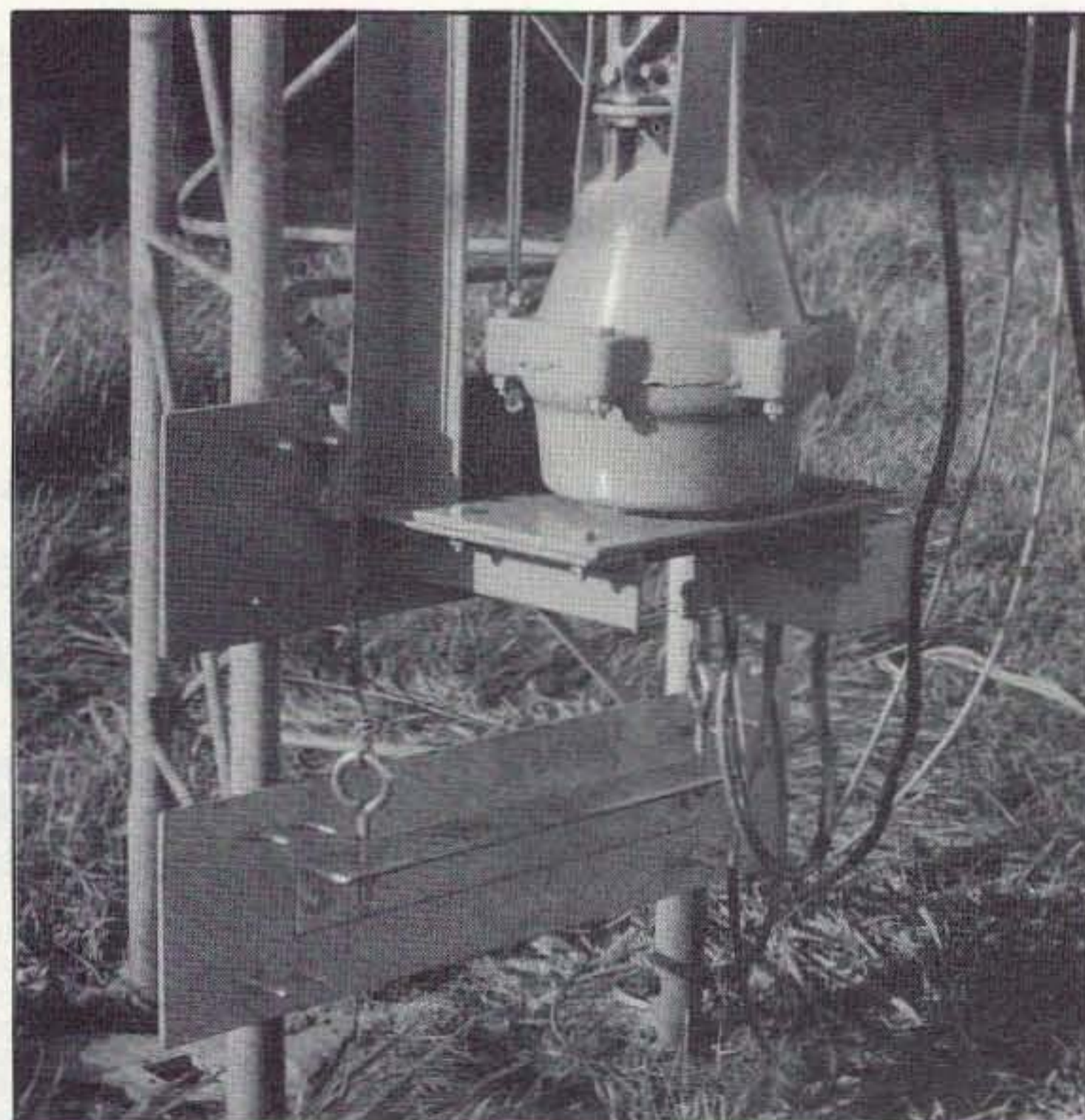

Photo B. The rotator and guide wires attached to their eye bolts and passing through the guides on the elevator.

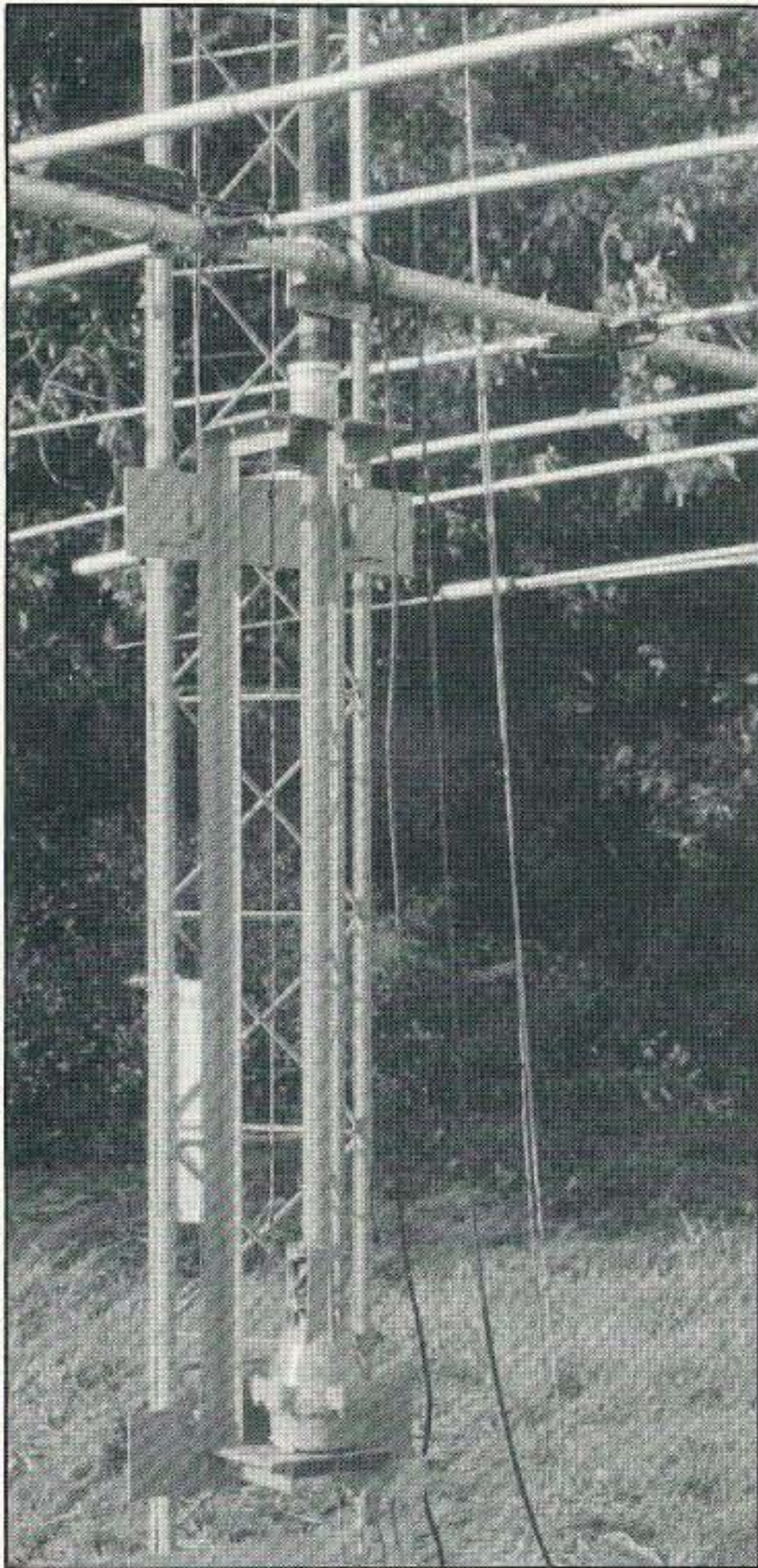

Photo C. The completed assembly, ready to be raised into position.

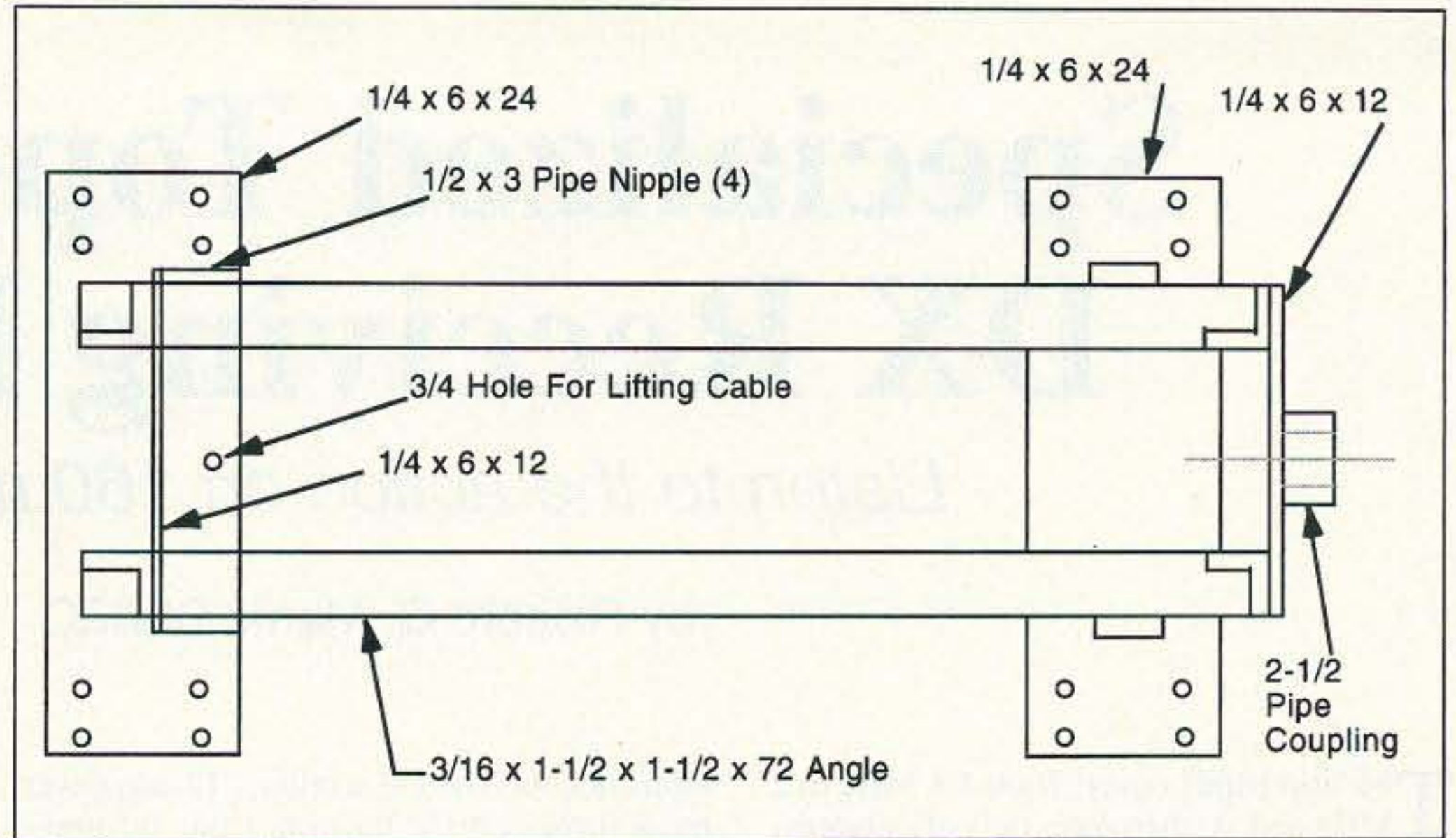

Figure 1. Top view of the elevator.

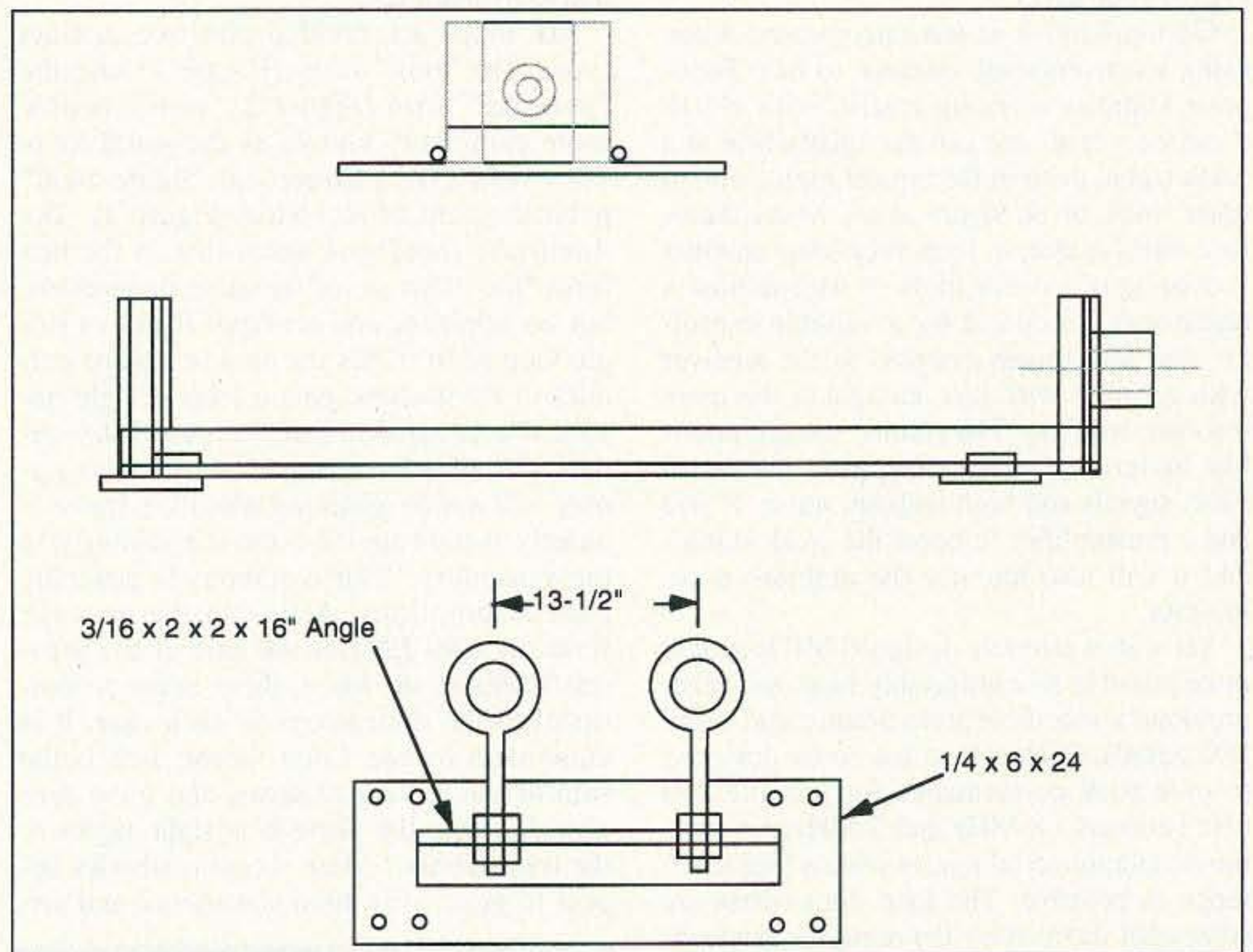

Figure 2. End view (top), side view (middle), and guide cable anchor (bottom).

bolt it together, it seems everyone knows someone with a welder. Or, it should not cost much to hire someone to do it.

Figures 1 and 2 show the dimensions I used, but these can be altered to suit your tower and rotator.

The antenna has been up for about one year now and everything is working fine. If I have to lower the antenna, it should take about an hour and require only two people working at a leisurely pace, safely!

73

The World of Ham Radio Callsign Jan 95 Database

You can have the latest US and Foreign callsigns available. 20,000+ software files for amateur radio. AmCall auto-logging station log book included with every CD. Over 1,350 Radio Mods. The latest space photos. The newest releases of amateur software. 1,100 images of lost & missing children. Thousands of SWL frequencies. Published every JAN/MAY/SEP Special rates for clubs, FTP, BBS, & PBBS sysops. DOS & Windows compatible. Can you afford to be without the biggest & best CD for amateur radio? Subscribe and get 3 issues for \$99 US, \$109 Foreign Single issues \$39 plus shipping: USA \$3, Overnight USA \$10, Foreign Air Mail \$5 AmSoft, PO Box 666, New Cumberland, PA 17070-0666 USA, FAX 717-938-6767



\$39
CD-ROM



AmSoft 717-938-8249

CIRCLE 113 ON READER SERVICE CARD

PORTABLE QRP CW TRANSCEIVER DEC. '90 & JAN. '91 QST BY GARY BREED K9AY



Features: SINGLE-SIGNAL receiver, VFO tuning, AGC for listening comfort, 5 Watts output, Semi-QSK TR switching and CW sidetone. Add a battery, key and antenna and you're on the air. FULL 100% KIT including a custom pre-painted, punched and lettered metal enclosure. 20, 30, 40 Meter available.

Complete Kit Only \$159.95

CA Residents add 7.75% sales tax. S&H: \$5.00 (insured). Foreign orders add 20%. For more info or price list; send legal size SASE (55¢) to:

Fax 714-952-3280 **A&A Engineering**  
2521 W. LaPalma #K • Anaheim, CA 92801 • 714-952-2114

Smart Battery Charger



JUN 87 QST
BY WARREN DION N1BBH

FOR GEL-CELLS or LEAD ACID BATTERIES.
Features: Precision temperature tracking voltage reference & three mode charging sequence. Standard kit is for 12V @ 1/2 or 1 Amp, user selectable. Can be connected to the battery indefinitely, will not overcharge. Weighs 2 pounds and measures 4"W x 5 1/2"D x 2 1/2"H. Finished enclosure included in kit.

Complete Kit Only \$59.95

Assembled & Tested \$79.95

CA Residents add 7.75% sales tax. S&H: \$5.00 (insured). Foreign orders add 20%. For more info or price list; send legal size SASE (55¢) to:

 **A&A Engineering** 
2521 W. La Palma #K • Anaheim, CA 92801
(714) 952-2114 • FAX: (714) 952-3280